

The Automated Extraction of Requirements from UML Models

Brian Berenbach

Siemens Corporate Research, Inc.
Brian.Berenbach@scr.siemens.com

1. Introduction

I have observed that often there is a disconnect between a UML model and the requirements of the modeled processes. This gap tends to widen as models become more complex and the extraction of detailed requirements becomes more difficult. Failure to develop a complete requirement set can have serious consequences later on, for example the derived test cases might not provide complete coverage. In an attempt to “bridge the gap” I devised an algorithm for the automatic extraction of requirements from complex UML models. The algorithm is fairly robust. I tested it on several complex models from Siemens operating companies and it worked quite well. One of the models tested had over 800 use cases; my success came as somewhat of a surprise (e.g. why isn’t everyone doing this?).

2. Extraction Algorithm

The process by which detailed requirements are extracted from a model is fairly straightforward. Not only can the technique be used to extract requirements, but, interestingly enough, the same information that is extracted can be used to generate the task list part of a project plan, as the concrete use cases identify the pieces of software that need to be implemented. They also correspond to the test cases that need to be generated!

The use case model is basically an acyclic directed graph, with dependencies (derived, «extend», «include») as vertices and use cases as nodes. By following the rules described in my talk, a set of trees of use cases is created, where each use case is a node in the tree with a derived, «extend» or «include» relationship with its parent. Abstract use cases become features and sub features; concrete use cases become detailed requirements for which project tasks may be created and test cases will be generated. An extracted requirements tree set can then be imported directly into a requirements tool. A block diagram outlining the logic for converting the directed graph to a set of hierarchical requirements is shown in figure 1.

3. Model Construction

In order for the extraction process to work, the use case model needs to be built following certain guidelines. For example: No dependency cycles and model continuity (e.g. a single continuous directed graph).

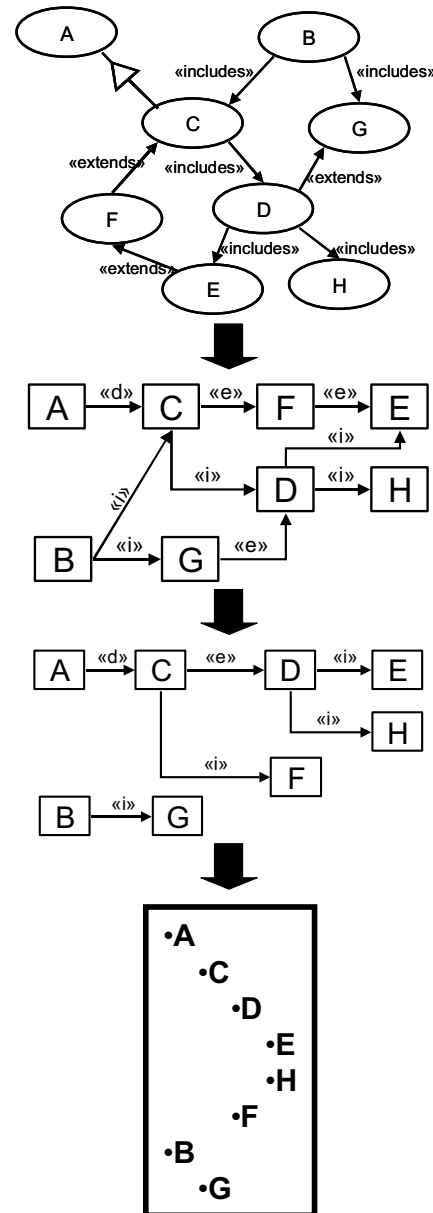

Figure 1 Extraction process

This talk will describe the techniques necessary to build a UML model from which requirements can be automatically extracted directly into a requirements database. I will also describe the logic of the algorithm so that any analyst who can write tool scripts can extend their CASE tool to support requirements extraction.