

A Performance Evaluation Model for Effective Job Scheduling in Global Computing Systems

Kento Aida
Tokyo Institute of Technology
aida@noc.titech.ac.jp

Atsuko Takefusa
Ochanomizu University
takefusa@hn.is.ocha.ac.jp

Hidemoto Nakada
Electrotechnical Laboratory
nakada@etl.go.jp

Satoshi Matsuoka
Tokyo Institute of Technology
matsu@is.titech.ac.jp

Umpei Nagashima
Ochanomizu University
umpei@is.ocha.ac.jp

Abstract

This paper proposes a performance evaluation model for effective job scheduling in global computing systems. The proposed model represents a global computing system by a queueing network, in which servers and networks are represented by queueing systems. Evaluation of the proposed model showed that the model could simulate behavior of an actual global computing system and job scheduling on the system effectively.

1 Introduction

Striking progress of network technology is enabling high-performance global computing, in which computational and data resources in a wide area network (WAN) are transparently employed to solve large-scale problems. Several high-performance global computing systems have already been proposed. Each of these systems proposes to effectively achieve high-performance with some efficient job scheduling scheme, whereby a scheduler selects a set of appropriate computing resources that solve the client's computational problem. These include the Ninf metaserver [4], NetSolve agent [3], AppLes [2], Prophet [5] and Nimrod [1].

Although these scheduling systems offer software mechanisms for resource location and scheduling, scheduling algorithms to effectively schedule multiple client jobs within a WAN on these systems have not been discussed well. Furthermore, although an appropriate performance evaluation model is necessary to accommodate effective scheduling schemes, models for job scheduling in global computing systems have not been well established. Experiments using actual global computing systems, as we have done in [4] could be a

partial solution, but experiments alone are not sufficient to evaluate performance of scheduling schemes in a general way.

We propose a performance evaluation model for effective job scheduling in global computing systems. The model represents a global computing system by a queueing network, and can be shown to properly characterize the global job scheduling in WAN settings.

2 Performance Evaluation Model

A global computing system can be assumed to consist of clients, servers and schedulers. A scheduler keeps information of servers and networks. When a client requests the execution of the job, the client queries the scheduler about a suitable server. Then, the client requests the server designated by the scheduler to execute client's job and transmits associated data to the server. The server executes the job and transmits its results to the client.

The scheduler should choose a suitable server for each client's request in order to minimize the response time of the request and to maintain high computing throughput in the global computing system. The performance of the scheduling algorithm is influenced by not only the server performance, CPU performance and congestion of jobs on the server, but also the network performance, bandwidth and congestion of traffic on the network between the client and the server. Therefore, the performance evaluation model is required to represent these primary factors effectively.

The proposed performance evaluation model employs a queueing network in which servers and networks are modeled as queueing systems. As shown on Figure 1, the server, the network from the client to the

server, and the network from the server to the client are represented by queues, Q_s , Q_{ns} , and Q_{nr} , respectively. Service rates on Q_s , Q_{ns} and Q_{nr} indicate the processing power of the server, the bandwidth of the network from the client to the server and that from the server to the client, respectively. Here, Clients A and A' denote the same client, but they are distinguished for notational convenience.

Jobs or data that arrive at Q_s , Q_{ns} and Q_{nr} are not confined to those from clients in a given global computing system, but also include those from other processes residing at all the nodes and elsewhere. Here, the arrival rate of jobs invoked from other processes to Q_s indicates the congestion of jobs on the server. Similarly, the arrival rate of data transmitted from other processes to Q_{ns} and Q_{nr} indicates the congestion of data on the network.

Arrivals of jobs and data are assumed to be following a certain distribution. We should employ the relevant distribution to the actual global computing system. The model can employ various distribution models for the arrival. Currently, we assume that the arrival to be Poisson, but are investigating more relevant distribution that can represents behavior of the actual WAN settings. Also, the arrival rates of jobs and data from other processes, which represent congestion of the server and the network, can be derived by mathematical formulas appropriately in the model.

As an example, in Figure 1, clients B and C are assumed to be located within the same local node, with an underlying assumption that both clients share the network to any given server. In order to represent this sharing, data transmitted from both B and C to the same server are simply queued into the same queue.

3 Conclusions

An appropriate performance evaluation model is necessary to evaluate general performance of scheduling schemes. However, the performance evaluation model for job scheduling in global computing systems has not been well established. We have proposed a performance evaluation model for job scheduling in global computing systems, based on queueing networks.

Currently, we are verifying the validity of our proposed performance evaluation model by comparison of the simulation result on the model with actual performance measurements using our global computing system, or Ninf [4]. Also we are evaluating several job scheduling schemes by simulation on the model. These evaluations exhibited the followings: (1)We found that the model could effectively simulate the communication throughput and overall client performance for sim-

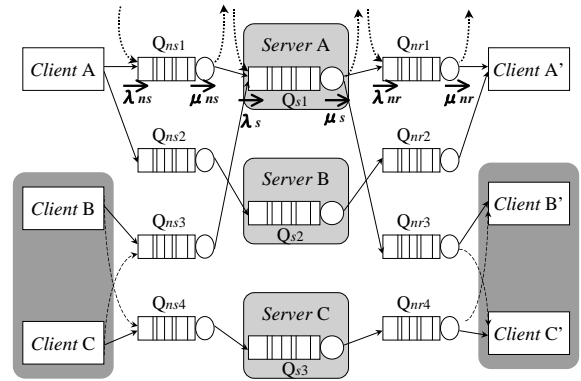

Figure 1. An Example of the Performance Evaluation Model

ple setups of our Ninf global computing systems effectively, in comparison to benchmark results on our testbed. (2)We confirmed that it could reproduce the phenomenon we observed for more complex global computing benchmark, namely, the false lowering of load information causing degradation of system performance for communication intensive jobs.

Furthermore, we are planning further investigation on the reliability of the proposed model, such as predicting the behavior of the network that is shared by multiple clients residing on the nodes at the same site, and better modeling of network congestion factors.

References

- [1] D. Abramson and J. Giddy. Scheduling Large Parametric Modelling Experiments on a Distributed Meta-Computer. In *PCW '97*, 1997.
- [2] F. Berman, R. Wolski, S. Figueira, J. Schopf, and G. Shao. Application-Level Scheduling on Distributed Heterogeneous Networks. In *Proc. of Supercomputing '96*, 1996.
- [3] H. Casanova and J. Dongarra. NetSolve: A Network Server for Solving Computational Science Problems. In *Proc. of Supercomputing '96*, 1996.
- [4] A. Takefusa, S. Matsuoka, H. Ogawa, H. Nakada, H. Takagi, M. Sato, S. Sekiguchi, and U. Nagashima. Multi-client LAN/WAN Performance Analysis of Ninf: a High-Performance Global Computing System. In *Proc. of the ACM/IEEE SC97 Conference*, 1997.
- [5] J. B. Weissman and X. Zhao. Scheduling Parallel Applications in Distributed Networks. *J. of Cluster Computing*, (to appear).