

K-Discovery: Using Topic Maps to Identify Distributed Knowledge Structures in Groupware-based Organizational Memories

Stefan Smolnik – Ludwig Nastansky

Department of Business Computing 2, University of Paderborn

Warburger Str. 100, D-33098 Paderborn, Germany

{Stefan.Smolnik|Ludwig.Nastansky}@notes.upb.de

Phone: +49-5251-603368, Fax: +49-5251-603399, <http://gcc.upb.de>

Abstract

Many of today's organizations already have a strong integration of groupware systems in their IT-infrastructure. The shared databases of these groupware systems form organizational memories, which comprise the complete knowledge of an organization collected over the time of its existence. One key problem is how to find relevant knowledge or information in continuously growing and distributed organizational memories. The basic functionalities and mechanisms in groupware systems are not sufficient to support users in finding required knowledge or information. Topic maps provide strong paradigms and concepts for the semantic structuring of link networks and therefore, they are a considerable solution for organizing and navigating large and continuously growing organizational memories. The K-Discovery project suggests applying topic maps to groupware systems to address the mentioned challenges. Thus, the K-Discovery project introduces a conceptual framework, an architecture and an implementation approach to create knowledge structures by generating topic maps in organizational memories.

1. Introduction and overview

Within many organizations, groupware-based environments are the basis of communication and information management. With an increasing integration of these environments in internal business processes, organizational memories grow fast. These shared databases often existing in groupware-based office systems, allow transformation of individual knowledge into common knowledge. Looking at the technical perspective of knowledge management, groupware seems to be a suitable platform for managing organizational memories [2] (cf. [3]). The growing flood of available information requires powerful concepts and mechanisms

to support users, who search for relevant information and knowledge objects. Mechanisms of navigation and linking as well as functionalities for extensive searches and investigations are needed to explore and to use complex offers of information and knowledge. These mechanisms and functionalities are a necessary condition for the core processes of knowledge identification and knowledge use [4]. Therefore, effective search mechanisms, which improve organizational use of existing individual and common information and knowledge objects, contribute to the process of knowledge generation, i.e. the development or collection of new knowledge [5].

Topic maps – as defined in ISO/IEC 13250 – used on information sets create knowledge structures and form a structured semantic link network upon a great set of information [6]. Thus, topic maps are a perfect basis to realize the mentioned mechanisms and functionalities for the identification of relevant information and knowledge objects. In this contribution, we describe the fundamental idea of the research project KDiscovery: Using topic maps to identify distributed knowledge structures in groupware-based organizational memories. In addition to the existing techniques of search and navigation, like hierarchical navigation in categories of views or full text search, the user can be supported by the strong concept of associative navigation in semantic networks (provided by topic maps) (cf. [7]). Further, a groupware-based implementation of topic maps benefits from several aspects in groupware paradigms and technologies, like distributed database architectures and replication, workflow management, or security and access control mechanisms.

The purpose of this paper is to support users in finding relevant knowledge or information in distributed organizational memories by combining groupware paradigms and topic maps. This contribution is structured as followed: In section 2, we briefly describe a specific case study of a groupware-based organizational memory system and we give a motivation for this work. The basic concepts of topic maps are shortly introduced in section 3.

In section 4, we present conceptual approaches of the K-Discovery project: Firstly, we introduce the primary idea of the research project: Applying topic maps to groupware-based organizational memories to identify distributed knowledge structures. Secondly, we define a concept of roles and groups involved in the topic map publishing process to provide a natural and suitable integration into the infrastructure and process models of an organization. And thirdly, we define workflows supporting and controlling this publishing process. Based on these conceptual approaches, in section 5 the K-Discovery project defines a framework and architecture for a groupware-based knowledge management system using topic maps. This architecture integrates repositories as well as interfaces to these repositories, and tools, that access the interfaces of the infrastructure model, the process model, and the topic map model of an organization. Furthermore, a suitable framework for a new kind of knowledge management applications – based on the underlying concepts and paradigms of groupware and topic maps – is provided. For example, the usage of topic maps addresses the challenge of analyzing workflows and enables the identification of implicit and inherent process knowledge. In addition, we present an implementation that realizes some of the functionalities of the introduced architecture and thus, enables a generic and nearly automatic generation of topic maps upon groupware-based organizational memories [by using various technologies like groupware technologies, relational database management systems, Java, XML]. Section 6 shortly discusses related research and work. Section 7 outlines concluding remarks, the current state of the project and the future opportunities.

2. Motivation and short case

As pointed out above, groupware-based office systems provide an excellent environment for organizational knowledge management. In many cases, however, the groupware infrastructure is used to support teams in communication, coordination and collaboration. (The delimitation of these three terms is not homogeneous in literature. For an overview of differing controversial viewpoints please consult Bornschein-Grass [8]. We are referring to the definition by Lotus [9].) Effective access mechanisms are needed because of an increasing amount of information and knowledge objects in shared information spaces of such a groupware-based infrastructure. The following short case illustrates the need for these mechanisms:

In the Lotus Notes/Domino environment, all benefits of integrated correspondence, office, document, workflow, knowledge and archive management are brought together by Pavone Enterprise Office (v. [10]). This office system is based on a powerful process management toolset and consists of modular components,

allowing users to mix and match in order to meet their requirements. Supporting components are databases that capture and reflect the organizational structure, to provide text building blocks and models as well as to deal with processes (e.g. definition, tracking, and escalation). Two external tools enable the graphic definition, creation and maintenance of the organizational structure and of the business processes. The core application provides functionalities for office organization, office communication, address management, correspondence and information management, and process optimization. [10]

Within the Groupware Competence Center of the University of Paderborn, Pavone Enterprise Office is used in almost every part of operative work. There are several core applications for different contexts, such as usual office work, web publishing, teaching and examinations, projects and cooperation, research, and literature. To be precise, the organizational memories consist of more than 30 databases with approximately more than 60,000 documents. Even though there are a lot of semantic relations between the information in these databases, it is not possible to navigate between them or to identify knowledge structures. The capabilities for accessing the information and knowledge objects are restricted to basic full text searching and navigating through context sensitive views and categories. Full text indexes are not sufficient for searching information and structures, like document types or taxonomies, are sometimes too constraining to qualify or to categorize information [11]. Furthermore, the usage and the scope of these techniques are limited to a single database.

Analogous to this practical case, many organizations have a strong integration of groupware-based systems both in their IT-infrastructure and in their working environment. [To name only two examples, look at Deutsche Bank and PriceWaterhouseCoopers. Both of them use an extensive IT-infrastructure based on Lotus Notes/Domino.] With growing organizational memories on the one side, and the lack of powerful, effective mechanisms and functionalities for navigating, linking, searching and investigating on the other side, the need for enhanced access mechanisms to explore and use a complex offer of information and knowledge is becoming more than evident.

Digression: The design of groupware-based applications

For a better understanding, we think it is quite useful to shortly describe the basic design elements of a groupware-based application. All applications consist of one or more databases. These databases hold the data, logic, and design elements for the application (v. fig. 1).

The basic design elements of a groupware-based application are pages, forms, fields, and views (v. [12]). A *page* is a design element that displays information. Pages can be used anywhere in an application where text,

graphics, or an embedded control are presented to users. *Forms*, like pages, display information. Everything that can be done with a page can be done with a form. The difference between forms and pages is that forms can be used to collect information. A form provides the structure for creating and displaying documents, and documents are used to store data in a database. The information collected in a form is saved as a *document*. Further, a form is used by a document as a template to provide the structure for displaying data. A *field* is the part of an application that collects data. Fields are created on forms in particular. Each field stores a single type of information, such as text, numbers, dates, or names. The information in a field is stored in an individual document. The contents of fields can then be displayed in documents and views. A *view* is a sorted or categorized list of documents. Views are the entry point to the data stored in a database. Every database must have at least one view; usually most databases have more than one view. [12]

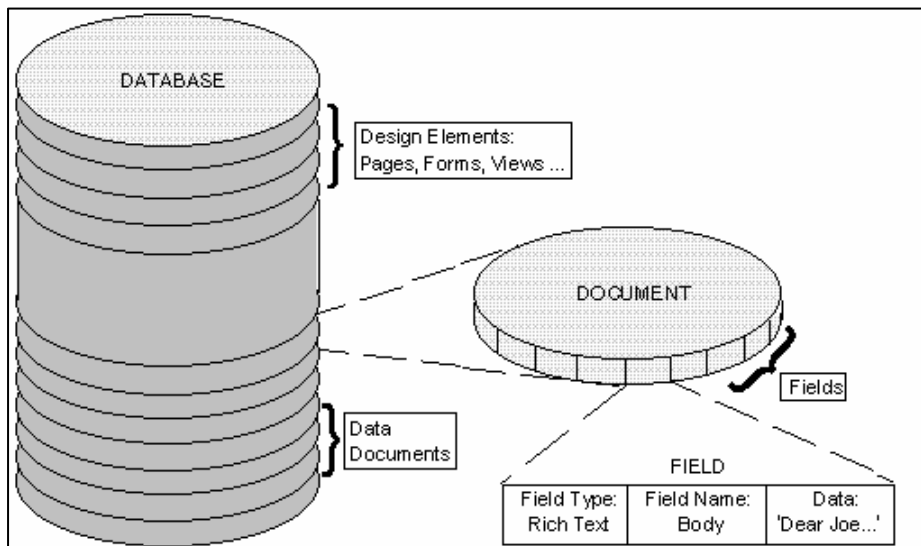

Figure 1. Design of a groupware-based application [12]

Apart from that, groupware-based applications consist of some more design elements that are of no interest in this context; therefore, they are not described here. For a comprehensive overview, refer to Lotus [12].

3. Introduction to topic maps

With the ongoing increase of information in the intranets of organizations as well as in the internet a need for new information management technologies emerges. So far, several technologies have been developed to address different aspects of the information management, e.g. computer networks, document management systems, workflow management or recently the different kinds of portals. As pointed out above, with growing

organizational memories on one side and the lack in powerful and effective mechanisms and functionalities for navigating, linking, searching and investigating on the other side, the need for enhanced access mechanisms to explore and use the complex offer of information and knowledge is getting more and more evident. To address these shortcomings the ISO standard *ISO/IEC 13250 Topic Maps* defines a model and architecture for the semantic structuring of link networks. By applying topic maps to large sets of heterogeneous information resources, reusable structured semantic link networks are created above those resources. Furthermore, the standard provides navigation paradigms to enable the search of knowledge structures [6].

The key concepts of topic maps are topics, occurrences of topics, and relationships between topics (topic associations). Firstly, a *topic* is a construct that represents a real world subject and in this sense a topic can be everything: a theme, a concept, a subject, a person, an entity, etc. (v. fig. 2). A concrete topic is an instance of a topic type. Therefore, a topic and a topic type form a class-instance relationship. At the same time a topic type is also a topic.

Topics have three kinds of characteristics: names, occurrences and roles in associations. Occurrences and roles in associations are described in detail later on. The base name of a topic is required. In addition, topics can have a display name and a sort name. These concepts apply to multilingual scenarios or to the use in different geographical

regions.

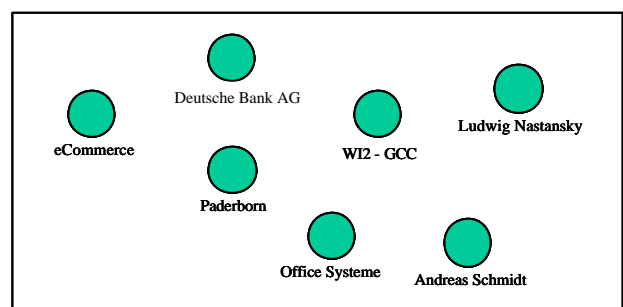

Figure 2. Topics

An *occurrence* is a link to one or more real information objects, like a report, a comment, a video or a picture (v. fig. 3). Generally, an occurrence is not part of a topic map. The link mechanism itself depends on the underlying system. For example, HyTime addressing,

XPointer or document links in a groupware-based system can be used as a link mechanism. To express different kinds of occurrences the standard provides the concept of occurrence roles that are topics as well.

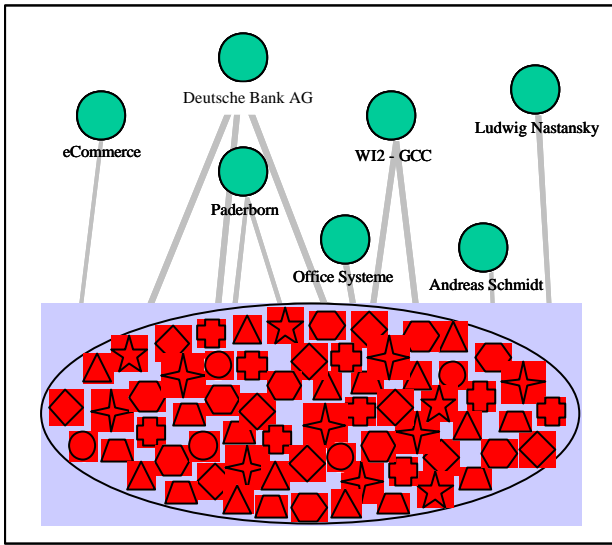

Figure 3. Occurrences

Topic associations describe the relationships between topics (v. fig. 4). They are completely independent of the real information object and represent the essential value-add of the topic map. This concept leads to some conclusions: A concrete topic map can be applied to different information repositories. Seen from the other side, different topic maps can be applied to one information repository and therefore, they can provide different views e.g. for different users. Furthermore, topic maps are interchangeable and they can be merged.

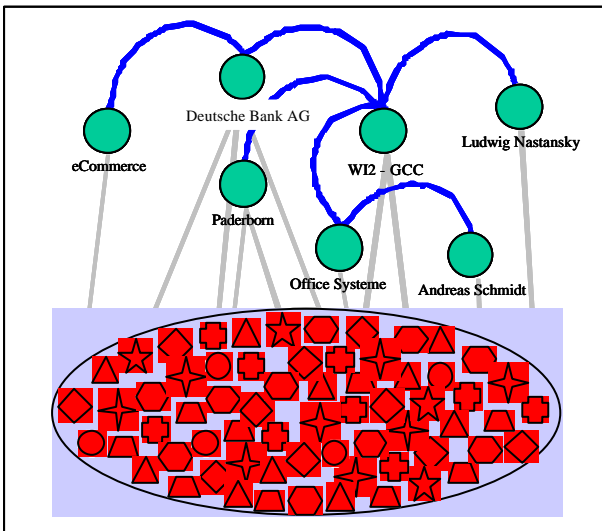

Figure 4. Topic associations

Generally, topic associations are not one-way relationships. They are symmetric as well as transitive

and thus, they have no direction. The construct of association types can be used to group topic associations and the involved topics. An association role describes the role of a topic in a topic association. Again, both the association types and the association roles are topics as well.

Additionally, the topic map standard provides the extended concepts of scope, public subject, and facets, which are not described here. For a comprehensive reference refer to Rath/Pepper [6] and ISO/IEC 13250 [13].

4. Conceptual approaches of the K-Discovery project

4.1. Using topic maps in groupware-based environments

By applying topic maps, as defined in ISO/IEC 13250, to groupware-based organizational memories, it is possible to close a gap between knowledge and information. So far, views and categories in groupware systems have enabled the creation of little knowledge by bringing documents in different contexts. But this concept is limited to a poor identification of relations between them. Topic maps provide appropriate concepts to overcome this limitation and to build a semantic link network from the documents of a database. The basic design elements of a groupware-based application, especially forms, can be used to identify the main subjects (topic types) and relationships between them (association types) (v. fig. 5).

While text analyzing methods with the support of artificial intelligence concepts could provide more or less reasonable results in identifying the main topics of a document, we have chosen another approach in the K-Discovery project. To identify the relevant subjects of documents, the fields of the forms must be considered. As mentioned before in the short case, in many groupware-based systems the information and knowledge objects, e.g. documents, contain many fields of various kinds and purposes: obvious information, like the parts of an address (e.g. city), or the category of a report (e.g. balance sheets 2000), or keywords and linking information (e.g. persons, locations, time, free or given keywords). These fields form a set of potential candidates for topic types. Moreover, by looking at the forms as a whole and at the views, a lot of basic associations can be found between topic types. For example, in the context of an address form, the associations “person lives in city” or “person works for company” can be identified. Similarly, a report form contains associations like “report is composed by person” or “report belongs to category”. When considering views, fields of forms are displayed in columns. These fields form a base for additional

associations, like “report is in work by person” in a workflow view. Obviously, the different forms, i.e. the different document types, can be regarded as occurrence roles, while documents are occurrences in a concrete topic map.

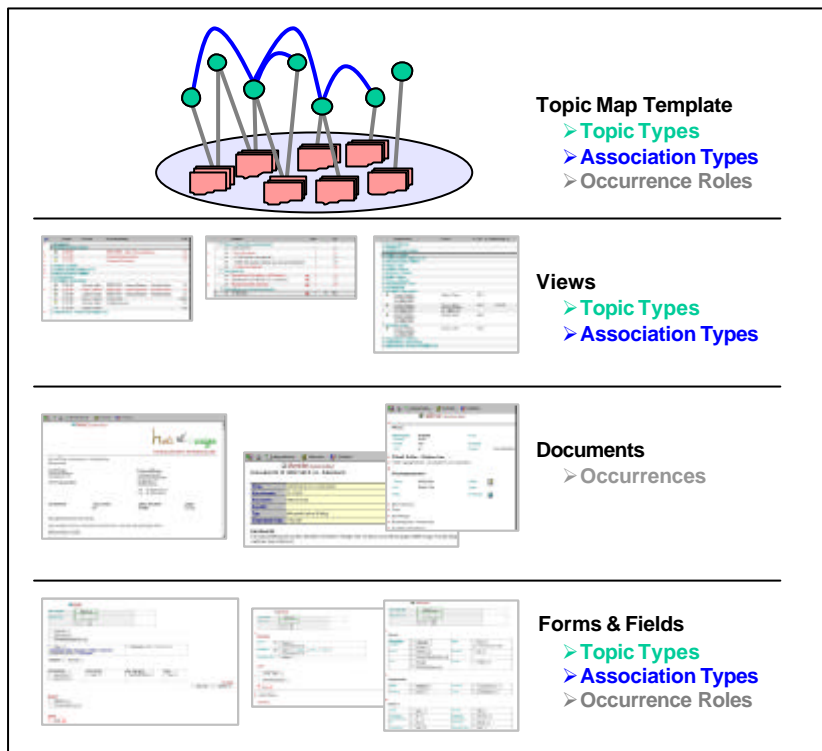

Figure 5. Concepts of topic maps and groupware

The consideration of the fields, forms, and views of a groupware-based application results in a template for a topic map. By applying this template to groupware-based organizational memories, a concrete topic map is built up. In particular, following the definitions of topic types, association types, and occurrence roles made in the template, topics, topic associations, and occurrences are derived from all documents in groupware-based organizational memories (for architectural and implementation approaches refer to section 5). These topics, topic associations, and occurrences form a topic map upon groupware-based organizational memories (v. fig. 6). This topic map provides a structured semantic link network and therefore, allows easy and selective navigation to the requested information and knowledge objects, independent from their origin (cf. [6]). In contrast to full text search and hierarchical navigation, searching in knowledge structures is enabled, i.e. search takes place in a meta level above information and knowledge objects, and transparent access to these objects is provided. Further, information and knowledge objects can be found in new contexts, regardless of potential categories in groupware-based organizational memories, and therefore, new contextual knowledge can be gathered (cf. [14, 15]).

To sum up, applying topic maps to groupware-based organizational memories provides a huge potential and a lot of advantages for the organizational knowledge management. Seen from the other side, groupware-based systems leverage the benefits of topic maps through their

basic concepts and paradigms, like distributed database architectures and replication, workflow management, or security and access control mechanisms [16]. A groupware-based environment enables the definition, generation and maintenance of a topic map in a consistent manner, on both a stationary and a mobile workstation. Thus, the distributed management of a topic map is independent of time and location. Differentiated access rights can be defined for a certain set of information objects, single information objects, and any part of an information object, as well as for functionality and presentation elements and design elements (like forms and views). These mechanisms enable the realistic adaptation of access structures against the background of complex and real organization models. As an example, some organizational members form an editorial team, which ensures that all published components of a topic map like topics, topic associations or occurrences

adhere to organizational standards. Another key concept of groupware-based systems, the workflow management, can be used to describe and support the whole process chain of topic map publishing. A model of an organizational integration of topic maps is introduced in section 4.2 and supporting workflows are defined in section 4.3.

The described concepts, paradigms, and functionalities of groupware-based systems enable the team-based and organizational wide use of topic maps. Both the groupware-based systems and the concept of topic maps leverage their mutual potentials.

4.2. Organizational integration of topic maps

The above mentioned adaptation of organizational access structures is supported by the assignment from persons to abstract organization and structure entities, called roles and groups. Thus, the different tasks, steps and skills involved in managing topic maps can be modeled with these roles and groups of a groupware-based system. Further, the design and creation of topic maps can be divided in subtasks because of the availability of templates [17]. Dependent on type and intensity of usage of topic maps, different user classes and user types can be identified (v. tab. 1).

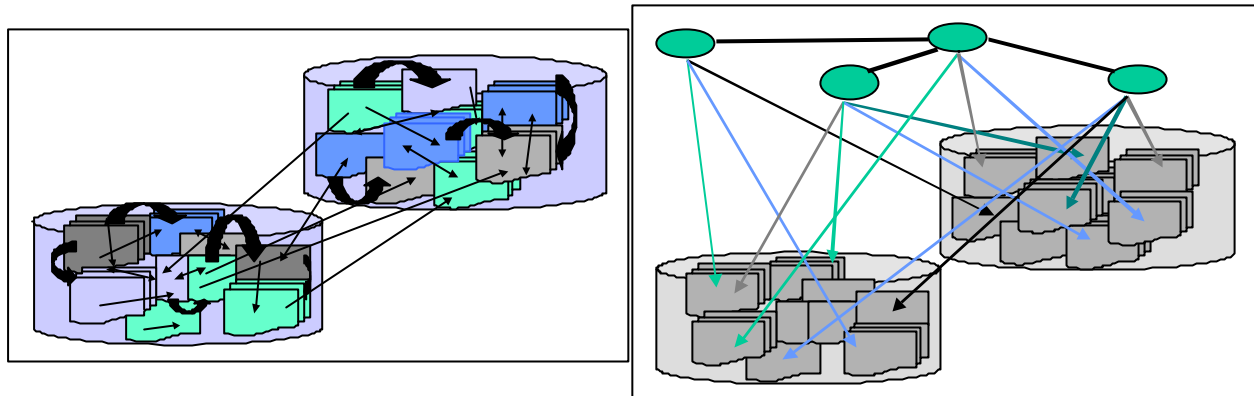

Figure 6. "Infoglut" (left) and a structured semantic link network (right)

Firstly, *end users* have read access to organizational topic maps. This access can be provided to entire topic maps or to specific parts of a topic map. For example, the scope of accesses depends on affiliations to projects, units, departments, or business processes. Personalization mechanisms enable customized access, i.e. based on personal profiles, specific parts of a topic map consisting of topics, topic associations, and occurrences are presented to end users. Push and pull mechanisms, e.g. subscribed newsletters or special views, are used to inform end users of available new topic map objects.

The second class of users are *knowledge authors*. They create new topics, topic associations, and occurrences but they are not allowed to publish or to archive them as well as to extend the publishing period. The creation of topic map objects is restricted to specific parts of a topic map, which again depend on affiliations to projects, units, departments, or business processes. At the end of the publishing period, the knowledge authors analyze their topic map objects and depending on their actuality, they apply for extending their publishing period or for archiving them.

In addition to the previous class of users, the *knowledge editors* are a content approval instance. They not only create topic map objects but also publish or archive them and extend publishing periods. Furthermore, they are responsible for the topic map objects which are created in their scope by knowledge authors. Knowledge editors generate added value by creating additional topic associations and occurrences because of their comprehensive overview. Again, all activities of knowledge editors are restricted to specific parts of a topic map.

So far, all classes have in common, that their users access only specific parts of a topic map (with the exception of the end users that may have read access to entire topic maps). Furthermore, the users of the first three classes are not allowed to assign access rights to other users. These issues are addressed by the class of *knowledge managers*. Knowledge managers maintain

entire organizational topic maps, i.e. they create, publish, and archive topic map objects in all parts of all topic maps. They extend publishing periods and analogous to knowledge editors, they generate added value by creating additional topic associations and occurrences because of their organizational-wide scope. Further, knowledge managers assign access rights to selected users and they initiate consistency checks based on conditions that are defined by the designers (v. below).

The last two user classes are less responsible for content related tasks. Their users perform more technical tasks like infrastructure or consistency issues.

Designers define topic types, association types, and occurrence roles. Thus, they create and maintain topic map templates. An additional task of designers is the definition of consistency conditions because real life topic maps will consist of millions of topics and topic associations. A manual check of a topic map of such a size is impossible, but necessary for proof-reading and quality assurance. Thus, an automatic process which validates a topic map against a set of consistency rules is needed [17].

The users of the last class, the *administrators*, are not involved in maintenance and authoring of topic maps. They are responsible for the technical infrastructure like servers, repositories, and the groupware environment.

4.3. Definition of supporting workflows

The process chain of topic map publishing, i.e. creation, publishing, archiving, and maintenance of topic map objects, can be described and supported by three workflows: a content approval workflow, a content expiry workflow, and an archiving workflow. For an introduction of basic terms and definitions in context of workflow management please consult Nastansky et al. [16], Picot/Rohrbach [18], WFMC [19], and Ott [20].

The *content approval workflow* ensures that all published contents adhere to the organizational standards. Topics, topic associations, and occurrences created by

Table 1. Groups and roles

<i>User class</i>	<i>Informational access</i>	<i>Creation of specific topic map objects</i>	<i>Maintenance of specific topic map objects</i>	<i>Maintenance of all topic map objects</i>	<i>Maintenance of topic map templates</i>	<i>Maintenance of technical infrastructure</i>
<i>Type and intensity of usage</i>	<i>Read access to topic maps</i>	<i>Creation of topics, topic associations, and occurrences</i>	<i>Maintenance of topics, topic associations, and occurrences of a specific organizational scope</i>	<i>Maintenance of all topics, topic associations, and occurrences as well as access rights</i>	<i>Maintenance of topic types, association types, and occurrence types as well as definition of consistency conditions</i>	<i>Maintenance of servers, repositories, and groupware environments</i>
<i>User type</i>	<i>End user</i>	<i>Knowledge author</i>	<i>Knowledge editor</i>	<i>Knowledge manager</i>	<i>Designer</i>	<i>Administrator</i>

knowledge authors are reviewed by knowledge editors or knowledge managers. If a knowledge editor or a knowledge manager approves a topic map object, it will be published for a specified period. Otherwise, it will be rejected and the knowledge author has to work on it again.

The *content expiry workflow* controls publishing dates and periods. Following the publishing date, topic map objects are resubmitted to their creators. They review them regarding correctness and actuality. If this review ends positive, again knowledge editors or knowledge managers decide if a topic map objects will be published further on.

The *archiving workflow* will come into effect at the end of a content expiry workflow if a topic map object is not correct or actual anymore and thus, it is no longer published. Knowledge authors apply for archiving topic map objects. Knowledge editors or knowledge managers decide about archiving them.

These workflows are embedded in the underlying technical infrastructure, the groupware-based environment. A groupware-based implementation of workflows forms a natural approach for supporting the process chain of topic map publishing.

5. Architectural considerations and implementation approach

From the previous section, we have learned that the organizational knowledge management benefits on the one hand from applying topic maps to groupware-based systems. On the other hand, these groupware-based systems provide an excellent environment for the integration of topic maps. In subsequent paragraphs, the basic architectural model of the K-Discovery project is introduced. The main purpose of the K-Discovery architectural model is to explain how functionality can be

provided and therefore, to specify separated modules that match the various requirements needed to gain the benefits addressed with the ideas of K-Discovery.

To keep the advantages of a flexible, structured and well-defined system, the architecture of the K-Discovery system is subdivided in several modular layers (v. fig. 7). These layers can be categorized into two main classes by considering their intended functionalities and purposes: the back-end-centric and the front-end-centric class. The back-end-centric class contains the technical infrastructure, and the data and information repositories. In contrast, the front-end-centric class encloses all the applications and tools, helping end users to interact.

The four layers of the back-end-centric class perform basic functionalities, like the communication and linkage of computer systems, and provide the groupware functionalities described in section 4. Moreover, the repositories for the elements of a topic map (for a detailed description see below), the organizational structure, and the process model are placed in this class.

The upper main half, consisting of three layers, forms the class of front-end-centric functionalities. The first of these layers provides several interfaces to the repositories. Their services are used by a set of tools which refer to the management of topic maps. Firstly, the *Groupware-based Topic Map Engine* (GTME) allows the definition and creation of topic maps. In particular, topic types and association types can be defined. Based on these definitions, a topic map can be created automatically. Secondly, the *Topic Map Navigator* (TMN) provides functionalities, especially for end users, to navigate and to search through a topic map. Thirdly, to modify an existing topic map, the *Topic Map Modeler* (TMM) offers the necessary capabilities. Some of these tools are exchangeable, because of the modular and open architectural approach, e.g. instead of the Topic Map Navigator described in detail below, a different product, like the *Ontopia Navigator*, can be integrated (v. [21]).

Several knowledge management applications can be developed upon these tools to support the organizational development and identification of knowledge. For example, consider the repository of processes. By applying a topic map to the set of run workflows, it is possible to identify relationships between them as well as implicit and inherent process knowledge. The resulting knowledge can be used in two ways: Firstly, to group similar workflows and to create predefined workflows. Secondly, it can support the analysis of the process structure as well as the organizational structure. A concrete application for distributing workflow process knowledge in organizations as well as for the semantic associative navigation in process networks is described in detail in Smolnik/Huth/Nastansky [22] and Huth/Smolnik/Nastansky [23].

“ReplicaID”). Connections to any groupware-based organizational memory can be established independent of their location; specifically, they can be hosted by different servers.

Topic types and association types are also defined in documents, each of which consists of an identifier and a base name. The definition of topics is supported by topic rules. Several parameters and even the possibility of using programmatic code – the formula language – enable the exact, intuitive, and easy definition of topics. Similar to these topic definitions, topic associations can be specified. Within association rules the involved topics and the relationship between them can be defined again by using several parameters and programmatic code. The creation of topic rules and association rules is supported by software assistants, and context sensitive dialogues that directly access the definitions of topic types and association types, as well as the designs of the organizational memories, especially the forms. Based on these definitions in the groupware-based configuration and management environment, software agents create and update tables in the relational repository for the objects of a topic map. They make the incremental maintenance of the data in the relational repository possible, i.e. not the complete data is updated every time changes are made; only the actual additions or deletions are carried out in the repository. The software agents and the used SQL statements reside in the groupware-based environment.

A Java servlet provides the navigation functionality and the front-end design (v. fig. 8). This Java servlet retrieves the topic map data from the relational repository by using SQL statements. All resources needed for the visualization, e.g. the Java servlet, HTML documents, image resources, are stored on a server.

The described implementation approach gains several benefits from the underlying groupware-based environment. The full concepts of security and access control, replication, and workflow management can be applied (v. section 4), because the entire configuration and management take place in the groupware-based environment. As pointed out in Rath/Pepper [6], topic maps can be considered as portable semantic networks. This portability is directly supported through the mechanisms of replication. Thus, a topic map template or parts of it can be managed and used in a distributed way and even on a local system. Furthermore, the overall performance of this implementation approach is high, because of the usage of a relational database management system as a repository for the objects of a topic map.

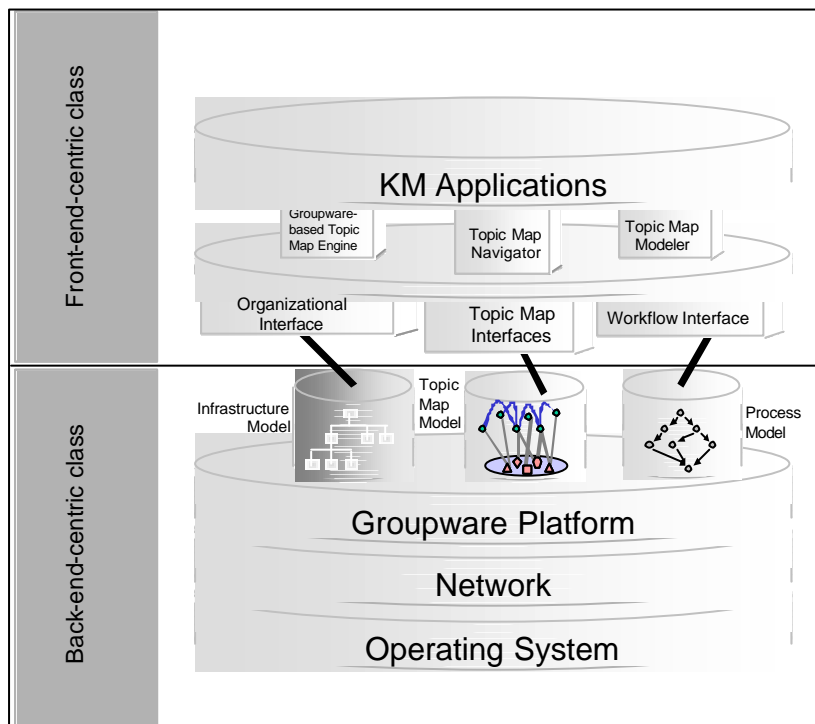

Figure 7. Architectural model of the K-Discovery project

Implementation approach

The implementation approach of core functionalities of the mentioned architecture uses the groupware-based environment for generation and configuration of a topic map and a relational database management system (concrete: an Oracle 8i database) functions as a repository for the objects of a topic map (v. fig. 8). To determine and to reference the organizational memories to which a topic map should be applied, database connection documents are created (in the groupware-based environment). They define all necessary information to locate these organizational memories, e.g. the server, the location on the server, and an unambiguous identifier (the

Possible time exhausting data lookups in a groupware-based repository are not necessary and therefore not implemented.

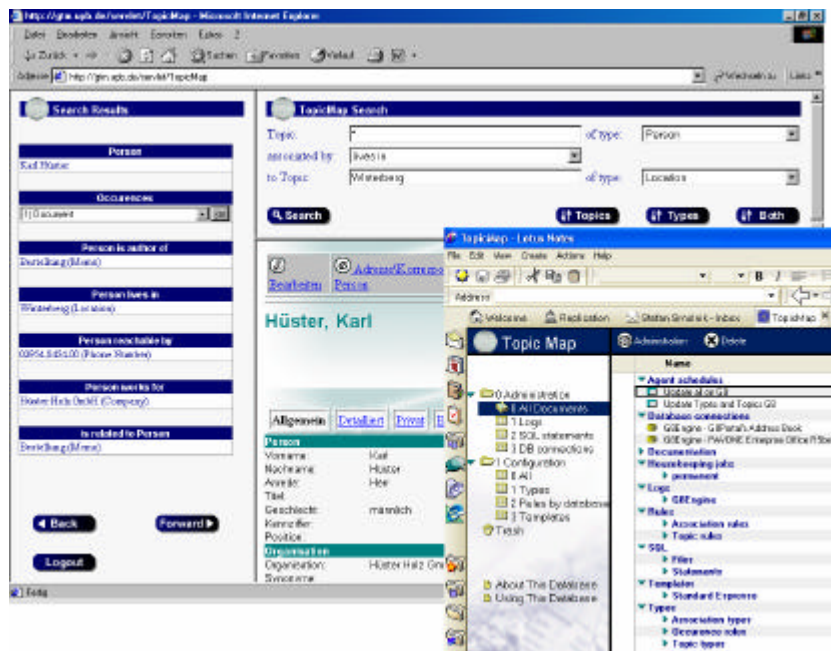

Figure 8. Configuration environment and front-end of the implementation approach

Functionalities for distributed maintenance of concrete topic maps, i.e. for the replication of topics and topic associations, are not completely implemented so far, but they are under development.

6. Related work

The approach of the K-Discovery project differs from other approaches in literature and from commercial products. Other current approaches or products based on topic maps, like the Ontopia Knowledge Suite (v. [21]) or the empolis K42 (v. [24]), provide a framework to manage and maintain topic maps. The tools include functionalities to build up topic maps manually, to load topic maps from XML documents, to store topic maps in databases, and to modify and access topic maps. These solutions have in common the manual construction and the XML-based representation of topic maps. Compared to the approach of the K-Discovery project, it is not possible to generate topic maps automatically or at least, to use support by software agents. Moreover, they are not naturally integrated in a groupware-based environment and thus, they can not gain the in section 4 mentioned benefits of combining groupware paradigms and topic maps. The Lotus Discovery Server automatically generates and maintains a “Knowledge Map” to display relevant content categories and their appropriate hierarchical mapping (v. [25]). Even though this solution

accesses groupware-based organizational memories, again there is no direct integration in a groupware-based environment. Additional, opposed to the semantic link network, which is given by a groupware-based topic map, a hierarchical mapping is provided. Other approaches (e.g. [26]) have a different focus, like enhancing workflow management system capabilities to gain synergies for organizational learning.

7. Conclusions and future areas of research

An architecture of a groupware-based knowledge management system based on the ISO standard *ISO/IEC 13250 Topic Maps* has been presented. The K-Discovery project combines groupware paradigms and topic maps, leading to substantial synergies for the organizational knowledge management. These leverage their mutual advantages and therefore, provide benefits for both

research fields. From our point of view, the K-Discovery project provides a considerable framework to identify knowledge structures in groupware-based environments and therefore, support users in finding needed knowledge or information in organizational memories. In addition, the findings are from high practical relevance as shown in the short case. In fact, there are already some companies that have shown interest in such a solution.

Prototypes of the core modules have been implemented and can be used for trial purposes. The finalization of the system integration is planned for the very near future. In detail, the implementations of the Groupware-based Topic Map Engine and the Topic Map Navigator were finished. The conception and implementation of the Topic Map Modeler is about to begin. However, work on the prototypes will be continued to integrate some additional functionalities in the existing core modules like the above mentioned distributed maintenance of topics and topic associations or personalization mechanisms.

Moreover, future works will focus on some further conceptions. For example, a graphical visualization of topic maps will be developed. So far, end users have to use the Topic Map Navigator, which provides a tabular and textual user interface. We have just begun to evaluate several graphical visualization approaches, like the Inxight Star Tree (v. [27]), to adopt one of them and to apply it to the Groupware-based Topic Map Engine.

Eventually, further knowledge management applications upon the Groupware-based Topic Map Engine will be developed. Specifically, taxonomy issues

in virtual organizations will be addressed.

References

- [1] Heijst, G. van; Spek, R. van der; Kruizinga, E.: Organising Corporate Memories; in: Proceedings of tenth Knowledge Acquisition for Knowledge-Based Systems Workshop, 1996.
- [2] Schliwka, A.: Teamorientiertes, medienübergreifendes Know-how-Management in verteilten Umgebungen; Shaker, Aachen 1998.
- [3] Davenport, Thomas H.; Prusak, Laurence: Working Knowledge – How Organizations Manage What They Know; Harvard Business School Press, Boston, Massachusetts, 1998.
- [4] Probst, G.; Raub, S.; Romhardt, K.: Wissen managen: Wie Unternehmen ihre wertvollste Ressource optimal nutzen; 3. Aufl., Gabler, Wiesbaden 1999.
- [5] Guldenberg, S.: Wissensmanagement und Wissenscontrolling in lernenden Organisationen: ein systemtheoretischer Ansatz; DUV: Wirtschaftswissenschaft, Edition Österreichisches Controller Institut, Zugl.: Wien, Wirtschaftsuniv., Diss., 1996 2. durchges. Auflage, DUV, Deutscher Universitäts-Verlag GmbH, Wiesbaden, 1998.
- [6] Rath, Dr. Hans Holger; Pepper, Steve: Topic Maps: Introduction and Allegro; in: Proceedings of the Markup Technologies 99, Philadelphia, USA, 1999.
- [7] Ahmed, Kal: Topic Maps for repositories; in: Proceedings of the XML Europe 2000, Paris, France, 2000.
- [8] Bornschein-Grass, C.: Einsatzformen und betriebswirtschaftliche Gestaltungspotentiale von Groupware als Grundlage von Computer Supported Cooperative Work; Deutscher Universitäts-Verlag, Wiesbaden, 1995.
- [9] Lotus Development Corporation: Groupware - Communication, Collaboration, Coordination; Cambridge, Massachusetts, USA, November, 1995.
- [10] Pavone AG: Enterprise Office Help [Release 4.6d, Build 320]; Database, Paderborn, 2001.
- [11] Biezunski, Michel; Newcomb, Steven R.: Topic Maps and XTM – A Manager's Overview; in: Proceedings of the Knowledge Technologies 2001 (KT2001), Austin, Texas, USA, 5-7 March 2001.
- [12] Lotus Development Corporation: Domino Designer Help [Release 5.06a]; Database, Cambridge, Massachusetts, USA, 2001.
- [13] International Organization for Standardization, ISO/IEC 13250, Information technology – SGML Applications – Topic Maps, Geneva: ISO, 2000.
- [14] Klemke, Roland: Context Framework – an Open Approach to Enhance Organisational Memory Systems with Context Modelling Techniques; in: Proceedings of the Third International Conference on Practical Aspects of Knowledge Management (PAKM2000), Basel, Switzerland, 30-31 October 2000.
- [15] Nonaka, Ikujiro; Takeuchi, Hirotaka: The Knowledge-Creating Company – How Japanese Companies Create the Dynamics of Innovation; Oxford University Press, New York, Oxford, 1995.
- [16] Nastansky, Ludwig; Bruse, Thomas; Haberstock, Philipp; Huth, Carsten; Smolnik, Stefan: Büroinformationssysteme, in: Fischer, J.; Herold W.; Dangelmaier, W.; Nastansky, L.; Suhl, L. (Hrsg.): Bausteine der Wirtschaftsinformatik, Erich Schmidt, Berlin, 2000.
- [17] Rath, Dr. Hans Holger: Technical Issues on Topic Maps; in: Proceedings of the Metastructures 1999, Montreal, Quebec, Canada, 1999.
- [18] Picot, A.; Rohrbach, P.: Organisatorische Aspekte von Workflow-Management-Systemen; in: Information Management, 10. Jg., 1995, Nr. 1, S. 28-35.
- [19] WFMC: Workflow Management Coalition: The Workflow Reference Model; Workflow Management Coalition (Hrsg.), Document Number TC00-1003, o. O. 1996.
- [20] Ott, M.: Organization Design as a Groupware-supported Team Process, GroupOrga – Participative and Distributed Organization Design for Office Information and Workflow Management Systems; Kluwer Academic Publishers, Dordrecht, The Netherlands, 1999.
- [21] Ontopia AS: Ontopia Software Products; <http://www.ontopia.net/solutions/products.html>, Oslo, Norway, 2001.
- [22] Smolnik, Stefan; Huth, Carsten; Nastansky, Ludwig: Distribution of Workflow Process Knowledge in Organizations, in: Proceedings of the 2. Oldenburger Forum Wissensmanagement, Oldenburg, Juni, 2001.
- [23] Huth, Carsten; Smolnik, Stefan; Nastansky, Ludwig: Applying Topic Maps to Ad Hoc Workflows for Semantic Associative Navigation in Process Networks, in: Proceedings of the 7th International Workshop on Groupware (CRIWG'2001), Darmstadt, IEEE Computer Society Press, Los Alamitos CA, Washington, Brussels, Tokio, September, 2001.
- [24] empolis UK Ltd.: K42 – Knowledge Server; <http://k42.empolis.co.uk>, Swindon, Great Britain, 2001.
- [25] Lotus Development Corporation: Lotus Discovery Server; <http://www.lotus.com/home.nsf/welcome/discoveryserver>, Cambridge, Massachusetts, USA, 2001.
- [26] Wargitsch, Christoph; Wewers, Thorsten; Theisinger, F.: An Organizational-Memory-Based Approach for an Evolutionary Workflow Management System - Concepts and Implementation, in: Proceedings of the 31st Hawaii International Conference on System Sciences, Hawaii, 1998.
- [27] Inxight Software, Inc.: Inxight Star Tree; <http://startree.inxight.com/>, Santa Clara, CA, USA, 2001.